

Dell EMC PowerEdge

R440 Technical Guide

Notes, cautions, and warnings

 **NOTE:** A NOTE indicates important information that helps you make better use of your product.

 **CAUTION:** A CAUTION indicates either potential damage to hardware or loss of data and tells you how to avoid the problem.

 **WARNING:** A WARNING indicates a potential for property damage, personal injury, or death.

© 2017 - 2019 Dell Inc. or its subsidiaries. All rights reserved. Dell, EMC, and other trademarks are trademarks of Dell Inc. or its subsidiaries. Other trademarks may be trademarks of their respective owners.

Contents

List of Figures.....	5
List of Tables.....	6
1 System overview.....	8
Introduction.....	8
New technologies.....	8
2 System features.....	10
Product comparison.....	10
Technical specifications.....	11
3 Chassis views and features.....	13
Front panel view and features.....	13
Back panel view and features.....	13
Internal chassis view.....	14
Security features.....	14
4 Processors.....	15
Supported processors.....	15
Chipset.....	19
5 System memory.....	20
General memory module installation guidelines.....	21
6 Storage.....	22
IDSDM or vFlash card.....	23
Boot Optimized Storage Subsystem (BOSS).....	23
Optical drives.....	23
Tape Drives.....	24
Boot Optimized Storage Subsystem.....	24
7 Networking and PCIe.....	26
PCIe expansion cards.....	26
8 Power, Thermal, and Acoustics.....	27
Power consumption and energy efficiency.....	27
Thermal and Acoustics.....	28
Power supply units.....	28
Acoustical design.....	28
9 Rack rails.....	30

10 Dell EMC OpenManage systems management.....	32
Server and Chassis Managers.....	33
Automation Enablers.....	33
Integration with third-party consoles.....	33
Connections for third-party consoles.....	33
Dell EMC Update Utilities.....	33
Dell resources.....	33
11 Appendix A. Additional specifications.....	35
Power supply specifications.....	35
System dimensions.....	36
Chassis weight.....	36
Video specifications.....	37
12 Appendix B. Standards compliance.....	38
13 Appendix C Additional resources.....	39
14 Appendix D. Support and deployment services.....	40
ProDeploy Enterprise Suite and Residency Services.....	40
ProDeploy Plus.....	40
ProDeploy.....	40
Basic Deployment.....	40
Residency Services.....	41
Deployment services.....	41
Remote Consulting Services.....	41
Data Migration Service.....	41
ProSupport Enterprise Suite.....	41
ProSupport Plus.....	41
ProSupport.....	42
ProSupport One for Data Center.....	42
Support Technologies.....	42
Additional professional services.....	43
Dell Education Services.....	43
Dell EMC Global Infrastructure Consulting Services.....	43
Dell EMC Managed Services.....	43

List of Figures

Figure 1. Front view 4 x 3.5 inch drive chassis.....	13
Figure 2. Front view 8 x 2.5 inch drive chassis.....	13
Figure 3. Front view 10 x 2.5 inch drive chassis.....	13
Figure 4. Back panel view of system with 2 PCIe expansion slots.....	13
Figure 5. Back panel view of system with 1 PCIe expansion slot.....	14
Figure 6. Boot Optimized Storage Subsystem (BOSS).....	24
Figure 7. Sliding rails.....	30
Figure 8. Static rails.....	30
Figure 9. Dell EMC OpenManage Portfolio.....	32
Figure 10. Dimensions of the PowerEdge R440 system.....	36
Figure 11. ProDeploy Enterprise Suite capabilities.....	40
Figure 12. ProSupport Enterprise Suite.....	41
Figure 13. ProSupport One for Data Center model.....	42
Figure 14. SupportAssist model.....	43

List of Tables

Table 1. New technologies.....	8
Table 2. Feature comparison.....	10
Table 3. Technical specifications.....	11
Table 4. Security features.....	14
Table 5. Supported Processors for R440.....	15
Table 6. Supported Memory.....	20
Table 7. DIMM Performance Details.....	20
Table 8. Supported RAS features.....	21
Table 9. Perc offering.....	22
Table 10. Supported drives.....	22
Table 11. Supported drives - NVMe SSD.....	22
Table 12. External storage.....	23
Table 13. BOSS RAID controller features.....	24
Table 14. PCIe expansion card riser configurations for PowerEdge R440.....	26
Table 15. Power tools and technologies.....	27
Table 16. Acoustical reference points and output comparisons.....	28
Table 17. Static and sliding rails.....	31
Table 18. Static rails adjustability.....	31
Table 19. Dell resources.....	33
Table 20. Power supply specifications.....	35
Table 21. Dimensions of the PowerEdge R440 system.....	36

Table 22. Chassis weight.....	36
Table 23. Supported video resolution options.....	37
Table 24. Industry standard documents.....	38
Table 25. Additional resources.....	39

System overview

Introduction

The Dell EMC PowerEdge R440 is 2-socket, 1U rack server designed to run complex workloads using highly scalable memory, I/O, and network options. The PowerEdge R440 is a general purpose platform expandable up to 1TB of memory, up to ten drives and flexible I/O options. The R440 can handle demanding workloads and applications such as data warehouses, e-commerce, databases, and High Performance Computing (HPC).

The R440 delivers the perfect combination of performance and density for HPC and web-tech deployments with a feature set right-sized for scale-out infrastructure environments.

NOTE: NOTE: 768 GB max memory is recommended for performance optimized configurations.

The R440 features:

- 2nd Generation Intel Xeon Scalable Processor product family (with up to 24 cores and two threads per core)
- Up to six channels with two DIMMs per channel per CPU and 16 DIMMs (supports DDR4 RDIMM and LRDIMM)
- PCI Express (PCIe) 3.0 enabled expansion slots (with up to 48 lanes per CPU)
- Networking technologies, such as Ethernet, Infiniband, OPA

New technologies

The following are the new technologies featured on the PowerEdge R440:

Table 1. New technologies

New technology	Detailed description
2nd Generation Intel Xeon Scalable Processor	The processor product family has embedded PCIe lanes for improved I/O performance. For details, see the Processor section.
Intel C620 series chipset	The R440 system uses the Intel C620 series chipset. It is a 2 chip platform - CPU and PCH.
2666 MT/s DDR4 memory	The Intel Xeon Scalable Processor product family that supports 2666 MT/s memory and sixteen 288-pin DIMMs. The R440 system supports: <ul style="list-style-type: none"> • Two DIMMs per channel for single-rank and/or dual-rank DIMMs • One or two DIMMs per channel for quad-rank DIMMs For details, see the Memory section.
iDRAC9 with Lifecycle Controller	The new embedded systems management solution for the Dell EMC systems features hardware and firmware inventory and alerting, data center level power monitoring, and faster performance. For details, see the Dell EMC OpenManage systems management section.
2.5-inch PCIe SSD	Supports up to ten CPU Direct Attach PCIe SSD
PERC S140	This new software RAID solution supports: <ul style="list-style-type: none"> • RAID 0, 1, 5, and Non-RAID

New technology

Detailed description

- SATA HDD and SSD devices only
- Up to ten 2.5 inch hot-plug SATA HDDs or SSDs
- Software RAID is through the Intel Lewisburg chipset
- Software RAID solution is supported on Linux and Windows

For details, see the Storage section.

LCD bezel

The PowerEdge R440 LCD control panel is embedded in an optional front bezel for easy access and management.

Wireless Management

The Quick Sync 2 BLE/Wi-Fi module offers support for access to the iDRAC GUI, SupportAssist Collections, remote RACADM, and VNC remote console connectivity.

System features

Compared to previous generations, the PowerEdge R440 offers faster processing power and advanced system management.

The PowerEdge R440 also provides extraordinary storage capacity options, making it well suited for data-intensive applications that require greater storage, while not sacrificing the I/O performance.

Topics:

- [Product comparison](#)
- [Technical specifications](#)

Product comparison

Table 2. Feature comparison

Feature	PowerEdge R440	PowerEdge R430
Processors	2nd Generation Intel Xeon Scalable Processor Family	Intel Xeon E5-2600 v3 or E5-2600 v4 processor
Chipset	Intel C620	Intel C610
Memory	16x DDR4 RDIMM, LRDIMM	12x DDR4 RDIMM, LR-DIMM
Disk Drives	3.5 inch, 2.5 inch - 12Gb SAS, 6Gb SATA and PCIe Storage (NVME)	3.5 inch, 2.5 inch - 12Gb SAS, 6Gb SATA
PCIe Slots	2x PCIe Gen3 (x16/x16)	2x PCIe Gen3 (x16/x8)
RAID Controller	<ul style="list-style-type: none"> • S140 • H330P • H730P • HBA330 • H740P • H840 • 12 Gbps External SAS HBA 	<ul style="list-style-type: none"> • S130 • H330 • H730 • H730P • H810 • H830
Backplane	<ul style="list-style-type: none"> • 10 x 2.5 inch SAS/SATA/NVMe • 8 x 2.5 inch SAS/SATA • 4 x 3.5 inch SAS/SATA 	<ul style="list-style-type: none"> • 10 x 2.5 inch SAS/SATA • 8 x 2.5 inch SAS/SATA • 4 x 3.5 or 2.5 inch SAS/SATA
Embedded NIC	2x 1Gb LOM and optional LAN on riser card: <ul style="list-style-type: none"> • 2x 1Gb • 2x 10Gb • 2x SFP+ 	4 x 1Gb LOM
Power Supplies	450 W AC Cabled PSU, 550 W AC PSU	450 W AC Cabled PSU, 550 W AC PSU
Remote Management	iDRAC9	iDRAC8
TPM	TPM 2.0 China, TPM1.2, TPM2.0	TPM China, TPM1.2, TPM2.0
Rear USB 3.0 port	Two rear ports	One rear port
iDRAC Direct front port	Micro USB	USB type A
Cooling Fan	Up to 6 fan support	Up to 6 fan support
IDSDM Module	Internal Dual SD Module (IDSDM) and vFlash	Internal Dual SD Module (IDSDM)
BOSS Module	M.2 SATA interface	None

Feature	PowerEdge R440	PowerEdge R430
PERC	Mini-PERC 9/10	Mini-PERC 9

Technical specifications

Table 3. Technical specifications

Feature	PowerEdge R440 technical specification
Form factor	1U rack
Processor	2nd Generation Intel Xeon Scalable Processor Family
Processor sockets	2 sockets
Internal interconnect	Up to 3 Intel Ultra Path Interconnect (Intel® UPI); up to 10.4 GT/s
Chipset	Intel C620 series Chipset
Memory	<ul style="list-style-type: none"> • Supports DDR4 RDIMM • Up to 512 GB RDIMM and 1 TB LRDIMM • 16 DIMM slots: 8 GB, 16 GB, 32 GB, 64 GB DDR4 up to 2666 MT/s
I/O slots	Up to 3 x PCIe Gen 3 slots plus a dedicated PERC and LOM slot
RAID controller	<p>Internal controllers: PERC H330, PERC H730P, HBA 330, PERC H740P</p> <p>External controllers: PERC H840 and 12 Gbps SAS HBA</p>
Hard drives	<ul style="list-style-type: none"> • 10 x 2.5 inch SAS/SATA – Up to 4 NVMe drives • 8 x 2.5 inch SAS/SATA • 4 x 3.5 inch SAS/SATA
Embedded NIC	<ul style="list-style-type: none"> • 2x 1Gb LOM and optional LOM riser: <ul style="list-style-type: none"> • 2x 1 Gb • 2x 10 Gb • 2x 10 Gb SFP+
Power supply	<p>Two back accessible, hot pluggable PSUs and option for single cabled PSU</p> <ul style="list-style-type: none"> • 550 W hot pluggable AC PSU • 450 W cabled AC PSU
Supported operating systems	<ul style="list-style-type: none"> • Canonical® Ubuntu® LTS • Citrix® XenServer® • Microsoft Windows Server® with Hyper-V • Red Hat® Enterprise Linux • SUSE® Linux Enterprise Server • VMware® ESXi <p>For more information on the specific versions and additions, visit Dell.com/OSsupport.</p>
Systems management	<p>Dell EMC Systems management consoles and tools:</p> <ul style="list-style-type: none"> • OpenManage Enterprise • OpenManage Mobile • OpenManage Power Manager <p>Embedded Management:</p> <ul style="list-style-type: none"> • iDRAC9 • iDRAC9 Direct • iDRAC REST API with Redfish

Feature

PowerEdge R440 technical specification

- Quick Sync 2 BLE/wireless module

Dell EMC OpenManage Integrations :

- Microsoft® System Center
- VMware® vCenter™
- BMC Truesight
- Red Hat® Ansible® Modules

Dell EMC OpenManage Connections:

- Micro Focus Operations Manager I
- Nagios Core and Nagios XI
- IBM Tivoli® Netcool/OMNIBus

Dimensions and weight

- Height: 42.80 mm — 1.69 inches
- Width: 482.0 mm — 18.97 inches
- Depth with bezel:
 - 10 x 2.5 inch
 - Front bezel to rear PSU handle: 714.58 mm (28.13 inches)
 - Front bezel to rear wall: 678.99 mm (26.73 inches)
 - 8 x 2.5 inch
 - Front bezel to rear PSU handle: 676.92 mm (26.65 inches)
 - Front bezel to rear wall: 663.96 mm (26.14 inches)
 - 4 x 3.5 inch
 - Front bezel to rear PSU handle: 714.58 mm (28.13 inches)
 - Front bezel to rear wall: 678.99 mm (26.73 inches)
- Depth without bezel:
 - 10 x 2.5 inch
 - Front bezel to rear PSU handle: 728.3 mm (28.67 inches)
 - Front bezel to rear wall: 692.63 mm (28.26 inches)
 - 8 x 2.5 inch
 - Front bezel to rear PSU handle: 677.45 mm (26.67 inches)
 - Front bezel to rear wall: 641.86 mm (25.27 inches)
 - 4 x 3.5 inch
 - Front bezel to rear PSU handle: 728.23 mm (28.67 inches)
 - Front bezel to rear wall: 692.63 mm (27.26 inches)

Recommended support

Dell ProSupport Plus for critical systems or Dell ProSupport for premium hardware and software support for your PowerEdge solution. Consulting and deployment offerings are also available.

Contact your Dell representative for more information. Availability and terms of Dell Services vary by region. For more information, visit [Dell.com/ ServiceDescriptions](https://www.dell.com/services).

Chassis views and features

The PowerEdge R440 is a two socket, 1U rack system that is available in three different chassis configurations:

- Four hard drive chassis
- Eight hard drive chassis
- Ten hard drive chassis

Topics:

- [Front panel view and features](#)
- [Back panel view and features](#)
- [Internal chassis view](#)
- [Security features](#)

Front panel view and features

The PowerEdge R440 provides three chassis options: 4 x 3.5 inch, 8 x 2.5 inch, or 10 x 2.5 inch drives.



Figure 1. Front view 4 x 3.5 inch drive chassis



Figure 2. Front view 8 x 2.5 inch drive chassis



Figure 3. Front view 10 x 2.5 inch drive chassis

Back panel view and features

The back panel of a PowerEdge system contains access to I/O connectors for both embedded and add-in devices, including networking, video, serial, USB, system ID, and system management access ports. Most add-in PCI cards are accessible through the back panel. It is also the default location for power supply units (PSU), including the points for AC/DC connections.



Figure 4. Back panel view of system with 2 PCIe expansion slots



Figure 5. Back panel view of system with 1 PCIe expansion slot

Internal chassis view

The chassis design of the PowerEdge R440 is optimized for easy access to components and for efficient cooling. The PowerEdge R440 supports up to 16 DIMMs, two processors, system board, hard drive bays, and many other components and features. For more system views, see the Dell EMC PowerEdge R440 Installation and Service Manual at Dell.com/Support/Manuals.

Security features

The latest generation of PowerEdge servers has the features listed in the table to help ensure the security of your data center.

Table 4. Security features

Security feature	Description
Cover latch	A tooled latch is integrated in the top cover to secure it to the system.
Bezel	A standard bezel is an optional metal bezel mounted to the chassis front. A lock on the bezel protects unauthorized access to hard drives. The Quick Sync NFC bezel enables the iDRAC QuickSync management function for managing the server from the front using an NFC-capable device and the free Dell EMC OpenManage Mobile App (currently Android only). Available only from the factory and not supported after point of sale.
TPM	The Trusted Platform Module (TPM) is used to generate/store keys, protect/authenticate passwords, and create/store digital certificates.
Power-off security	BIOS has the ability to disable the power button function.

Processors

The PowerEdge R440 server features the exceptional performance, value, and power efficiency of the 2nd Generation Intel Xeon Scalable processor family. These processors provide high performance no matter what your constraint—floor space, power, or budget—and on workloads that range from the most complicated scientific exploration to crucial web-serving and infrastructure applications. In addition to providing raw performance gains, improved I/O is also made possible with Intel Integrated I/O, which can reduce latency by adding more lanes and doubling bandwidth. This helps to reduce network and storage bottlenecks, which improves the processor performance capabilities.

The 2nd Generation Intel Xeon Processor Scalable Family provides the foundation for a powerful data center platform. It is the most advanced compute core featuring a new core micro architecture optimized to accelerate a wide range of compute workloads. The key features are as follows:

- **Higher Per-Core Performance:** Up to 28 cores (24 cores with R440), delivery high performance, and scalability for compute-intensive workloads across compute, storage, and network usages. The 2nd Generation Intel Xeon Scalable Processors can offer even greater core or frequencies, or both.
- **Greater Memory Bandwidth/Capacity:** 50% increased memory bandwidth and capacity. 6 memory channels vs. 4 memory channels of previous generation for memory intensive workloads.
- **Expanded I/O:** 48 lanes of PCIe 3.0 bandwidth and throughput for demanding I/O-intensive workloads.
- **Intel Ultra Path Interconnect (UPI):** Up to three Intel UPI channels increase scalability of the platform to as many as eight sockets, and improves inter-CPU bandwidth for I/O intensive workloads.
- **Intel Advanced Vector Extensions 512 (Intel AVX-512)** with a single AVX512 fused multiply add (FMA) execution units. SKUs which support Advanced RAS enable a second FMA execution unit.
- **Security without Compromise:** Near-zero encryption overhead enables higher performance on all secure data transactions with enhanced hardware mitigation.
- **Intel Deep Learning Boost:** Accelerate data-intensive workloads within the CPU with inferencing capabilities.

Topics:

- [Supported processors](#)
- [Chipset](#)

Supported processors

Table 5. Supported Processors for R440

Model	Intel SKU	SKU type	Speed (GHz)	Cache (MB)	UPI (GT/s)	Max Memory Speed (MT/s)	Cores	Turbo	TDP (W)
Intel Xeon Scalable Processor Family	6152	Gold	2.1	30	10.4	2666	22/44	Turbo	140
Intel Xeon Scalable Processor Family	6140	Gold	2.3	25	10.4	2666	18/36	Turbo	140
Intel Xeon Scalable Processor Family	6132	Gold	2.6	19	10.4	2666	14/28	Turbo	140
Intel Xeon Scalable Processor Family	6130	Gold	2.1	22	10.4	2666	16/32	Turbo	125

Model	Intel SKU	SKU type	Speed (GHz)	Cache (MB)	UPI (GT/s)	Max Memory Speed (MT/s)	Cores	Turbo	TDP (W)
Intel Xeon Scalable Processor Family	6126	Gold	2.6	19.25	10.4	2666	12/24	Turbo	125
Intel Xeon Scalable Processor Family	6230	Gold	2.1	27.50	10.4	2933	20	Turbo	125
Intel Xeon Scalable Processor Family	6209U	Gold	2.1	27.5	10.4	2933	20	Turbo	125
Intel Xeon Scalable Processor Family	6262V	Gold	1.9	33	10.4	2400	24	Turbo	135
Intel Xeon Scalable Processor Family	6226	Gold	2.7	19.25	10.4	2933	12	Turbo	125
Intel Xeon Scalable Processor Family	6234	Gold	3.3	24.75	10.4	2933	8	Turbo	130
Intel Xeon Scalable Processor Family	6238	Gold	2.1	30.25	10.4	2933	22	Turbo	140
Intel Xeon Scalable Processor Family	6240	Gold	2.6	24.75	10.4	2933	18	Turbo	150
Intel Xeon Scalable Processor Family	6242	Gold	2.8	22	10.4	2933	16	Turbo	150
Intel Xeon Scalable Processor Family	6252	Gold	2.1	35.75	10.4	2933	24	Turbo	150
Intel Xeon Scalable Processor Family	6248	Gold	2.5	27.50	10.4	2933	20	Turbo	150
Intel Xeon Scalable Processor Family	6222V	Gold	1.8	27.5	10.4	2400	20	Turbo	115
Intel Xeon Scalable Processor Family**	5122	Gold	3.6	16.5	10.4	2666	4/8	Turbo	105

Model	Intel SKU	SKU type	Speed (GHz)	Cache (MB)	UPI (GT/s)	Max Memory Speed (MT/s)	Cores	Turbo	TDP (W)
Intel Xeon Scalable Processor Family	5120	Gold	2.2	19	10.4	2666	14/28	Turbo	105
Intel Xeon Scalable Processor Family	5118	Gold	2.3	16	10.4	2666	12/24	Turbo	105
Intel Xeon Scalable Processor Family	5117	Gold	2.0	19.25	10.4	2666	10	Turbo	105
Intel Xeon Scalable Processor Family	5220	Gold	2.2	24.75	10.4	2666	18	Turbo	125
Intel Xeon Scalable Processor Family	5218	Gold	2.3	22.00	10.4	2666	16	Turbo	125
Intel Xeon Scalable Processor Family	5218R	Gold	2.1	27.50	10.4	2666	20	Turbo	125
Intel Xeon Scalable Processor Family	5222	Gold	3.8	16.50	10.4	2933	4	Turbo	105
Intel Xeon Scalable Processor Family	5215	Gold	2.5	13.75	10.4	2666	10	Turbo	85
Intel Xeon Scalable Processor Family	5217	Gold	3.0	11.00	10.4	2666	8	Turbo	115
Intel Xeon Scalable Processor Family	4116	Silver	2.1	16	9.6	2666	12/24	Turbo	85
Intel Xeon Scalable Processor Family	4215R	Silver	3.2	11	9.6	2400	8	Turbo	130
Intel Xeon Scalable Processor Family	4114	Silver	2.2	14	9.6	2666	10/20	Turbo	85
Intel Xeon Scalable Processor Family	4112	Silver	2.6	8.25	9.6	2666	4/24	Turbo	85

Model	Intel SKU	SKU type	Speed (GHz)	Cache (MB)	UPI (GT/s)	Max Memory Speed (MT/s)	Cores	Turbo	TDP (W)
Intel Xeon Scalable Processor Family	4110	Silver	2.1	11	9.6	2666	8/16	Turbo	85
Intel Xeon Scalable Processor Family*	4108	Silver	1.8	11	9.6	2666	8/16	Turbo	85
Intel Xeon Scalable Processor Family	4210R	Silver	2.4	13.75	9.6	2400	10	Turbo	100
Intel Xeon Scalable Processor Family	4214	Silver	2.2	16.50	9.6	2400	12	Turbo	85
Intel Xeon Scalable Processor Family	4214R	Silver	2.4	16.50	9.6	2400	12	Turbo	100
Intel Xeon Scalable Processor Family	4215	Silver	2.5	11.00	9.6	2400	8	Turbo	85
Intel Xeon Scalable Processor Family	4216	Silver	2.1	22.00	9.6	2400	16	Turbo	100
Intel Xeon Scalable Processor Family	4208	Silver	2.1	11.00	9.6	2400	8	Turbo	85
Intel Xeon Scalable Processor Family	4210	Silver	2.2	13.75	9.6	2400	10	Turbo	85
Intel Xeon Scalable Processor Family	3204	Bronze	1.9	8.25	9.6	2133	6	Turbo	85
Intel Xeon Scalable Processor Family	3206R	Bronze	1.9	11	9.6	2133	8	No	85
Intel Xeon Scalable Processor Family*	3106	Bronze	1.7	11	9.6	2666	8/8	No	85
Intel Xeon Scalable Processor Family**	3104	Bronze	1.7	8	9.6	2666	6/6	No	85

Processor Configurations

The R440 supports two processors with up to 24 cores per processor.

Single CPU Configuration

The R440 functions normally if there is just a single processor placed in the CPU1 socket. The system boots if only CPU2 socket is populated.

Processor Installation

For processor installation instructions, see the Dell PowerEdge R440 Installation and Service Manual at Dell.com/Support/Manuals.

Chipset

The following table shows the high level features supported by the chipset implemented on the PowerEdge R440:

- ACPI Power Management Logic Support, Revision 4.0a
- PCI Express Base Specification, Revision 3.0
- Integrated Serial ATA host controller, supports data transfer rates of up to 6 GB/s on all ports
- xHCI USB controller with SuperSpeed USB 3.0 ports
- Direct Media Interface
- Serial Peripheral Interface
- Enhanced Serial Peripheral Interface
- Flexible I/O - Allows some high-speed I/O signals to be configured as the PCIe root ports, the PCIe uplink for use with certain PCH, SATA (and sSATA), or USB 3.0.
- General Purpose Input Output (GPIO)
- Low Pin Count interface, interrupt controller, and timer functions
- System Management Bus Specification, Version 2.0
- Integrated Clock Controller, Real Time Clock Controller
- Intel High Definition Audio and Intel® Smart Sound Technology
- Integrated 10/1 Gb Ethernet
- Integrated 10/100/1000 Mbps Ethernet MAC
- Supports Intel Rapid Storage Technology Enterprise
- Supports Intel Active Management Technology and Server Platform Services
- Supports Intel Virtualization Technology for Directed I/O
- Supports Intel Trusted Execution Technology
- JTAG Boundary Scan support
- Intel Trace Hub for debug

For more information, visit Intel.com

System memory

The PowerEdge R440 support up to 16 DIMMs, with up to 1 TB of memory and speeds of up to 2666MT/s.

NOTE: 768 GB max memory is recommended for performance optimized configurations.

Supported DIMM types are:

- RDIMMs (Registered DIMM) - Provides for higher capacity options and advanced RAS features. It is the most commonly used DIMM type, and offers the best mix of frequency, capacity, and rank structure choices. LRDIMMs (Load Reduced DIMM) - Provides maximum capacity beyond that of an RDIMM but at a higher power consumption. Uses a buffer to reduce memory loading to a single load on all DDR signals, allowing for greater density.
- LRDIMMs (Load Reduced DIMM) - Provides maximum capacity beyond that of an RDIMM but at a higher power consumption. Uses a buffer to reduce memory loading to a single load on all DDR signals, allowing for greater density.

Supported memory

The R440 support registered (RDIMMs) and Unbuffered DIMMs (UDIMMs) is not supported for R440 system.

Table 6. Supported Memory

Feature	R440 (DDR4)
DIMM type	RDIMM, LRDIMM
Transfer speed	2666 MT/s 2400 MT/s 2133 MT/s 1866 MT/s
Voltage	1.2 V

Memory speed

The R440 supports memory speeds of 2666 MT/s, 2400 MT/s, 2133 MT/s, and 1866MT/s depending on the DIMM types installed and the configuration. The default speed is the highest common supported speed between the CPUs and DIMMs. The operating speed of the memory is also determined by the maximum speed that is supported by the processor, the speed settings in the BIOS, and the operating voltage of the system.

Table 7. DIMM Performance Details

DIMM type	DIMM ranking	Capacity	DIMM rated voltage, speed	The 2 nd Generation Intel® Xeon® Processor scalable processor family	
				1 DPC	2 DPC
RDIMM	1R/2R	8 GB, 16 GB, 32 GB	DDR4 (1.2 V), 2666	2666 MT/s	2666 MT/s
LRDIMM	2R	64 GB	DDR4 (1.2 V), 2666	2666 MT/s	2666 MT/s

Topics:

- [General memory module installation guidelines](#)

General memory module installation guidelines

Memory Configurations

NOTE: Memory configurations that fail to observe these guidelines can prevent system from booting, stop responding during memory configuration, or operating with reduced memory.

The PowerEdge R440 system support flexible memory configurations ranging from capacities of 8 GB to 1 TB. CPU1 supports up to 10 DIMMs. CPU2 supports up to 6 DIMMs. The R440 system supports memory configuration according to the following population rules:

- Mixing DIMMs with different rank is supported with condition of not more than two different ranks of DIMMs can be installed in a system.
- Speed: If memory modules with different speeds are installed, they operate at the speed of the slowest installed memory module(s) or slower depending on the system DIMM configuration.
- DIMMs with different data widths can be mixed. DIMMs with x4 and x8 data widths are supported and mixing is allowed.
- When mixing memory modules with different capacities, populate the sockets with memory modules with highest capacity first. For example, slot A1 populated first, then A2, and so on... The second CPU mirrors the first CPU population.

Memory RAS features

Reliability, availability, and serviceability (RAS) features help keep the system online and operational without significant impact to performance, and can decrease data loss and being unresponsive due to errors. RAS aids in rapid, accurate diagnosis of faults which require service.

Table 8. Supported RAS features

Feature	Description
Dense configuration optimized profile	Increased memory reliability can be a result from this selectable platform profile that adjusts parameters to reduce faults regarding refresh rates, speed, temperature, and voltage.
Memory demand and patrol scrubbing	Demand scrubbing is the ability to write corrected data back to the memory once a correctable error is detected on a read transaction. Patrol scrubbing proactively searches the system memory, repairing correctable errors.
Recovery from single DRAM device failure (SDDC)	Recovery from Single DRAM Device Failure (SDDC) provides error checking and correction that protects against any single memory chip failure and multi bit errors from any portion of a single memory chip.
Failed DIMM isolation	This feature provides the ability to identify a specific failing DIMM channel pair, thereby enabling the user to replace only the failed DIMM pair.
Memory mirroring	Memory mirroring is a method of keeping a duplicate (secondary or mirrored) copy of the contents of memory as a redundant backup for use if the primary intra-socket memory fails. The mirrored copy of the memory is stored in memory of the same processor socket.
Memory address parity protection	This feature provides the ability to detect transient errors on the address lines of the DDR channel.
Memory sparing (rank)	Memory sparing allocates one rank per channel as a spare. If excessive correctable errors occur in a rank or channel, they are moved to the spare area while the operating system is running to prevent the errors from causing an uncorrectable failure.
Memory thermal throttling	This feature helps to optimize power/performance and can also be used to prevent DIMMs from overheating.

Storage

The PowerEdge R440 provides scalable storage that allows you to adapt to your workload and operational requirements. With comprehensive storage options, the PowerEdge R440 offers various internal and external storage controllers, drive types, and different chassis and backplanes for varied numbers of drives. Features such as Express Flash PCIe SSDs, PERC H740P, and H840 RAID controllers provide vastly accelerated performance compared to the previous technologies.

PERC series controller offerings

The following table describes the PERC series controller supported by the PowerEdge R440:

Table 9. Perc offering

Performance level	Controller and description
Entry	<ul style="list-style-type: none"> S140-SATA, NVMe (SW RAID) SATA, NVMe
Value	<ul style="list-style-type: none"> HBA330-Internal, 12 Gbps SAS HBA-External H330, 12 Gbps SAS HBA-External
Value Performance	H730P
Premium Performance	H740P, H840

Supported drives - SAS and SATA

The following table lists the internal drives supported by the PowerEdge R440:

Table 10. Supported drives

Form factor	Type	Speed	Rotational speed	Capacity
2.5 -inch	SATA, SSD	6 Gb	N/A	240 GB, 400 GB, 480 GB, 800 GB, 960 GB, 1.6 GB, 1.9 GB, 3.2 GB, 3.8 GB
	SATA	6 Gb	7.2 K	1 TB, 2 TB
	SAS	12 Gb	7.2 K	1 TB, 2 TB, 2 TB-SED FIPS
	SAS, SSD	12 Gb	N/A	400 GB, 480 GB, 800 GB, 960 GB, 1.6 GB, 1.9 GB, 3.8 TB, 7.68 TB, 800 GB(SED FIPS), 1.6 GB-SED FIPS
	SAS	12 Gb	10 K	300 GB, 600 GB, 1.2 TB, 1.8 TB, 2.4 TB, 1.2 TB(SED FIPS), 2.4 TB-SED FIPS
	SAS	12 Gb	15 K	300 GB, 600 GB, 900 GB, 900 GB-SED FIPS
3.5 -inch	SATA	6 Gb	7.2 K	1 TB, 2 TB, 4 TB, 8 TB, 10 TB, 12 TB, 16 TB
	SAS	12 Gb	7.2 K	1 TB, 2 TB, 4 TB, 8 TB, 10 TB, 4 TB (SED FIPS), 8 TB-SED FIPS

Table 11. Supported drives - NVMe SSD

NVMe SSD drives description
375 GB 2.5-inch Device
1.6 TB 2.5-inch Device
3.2 TB 2.5-inch Device

NVMe SSD drives description

3.84TB 2.5 -inch Device

6.4TB 2.5 -inch Device

Table 12. External storage

Device Type	Description
External Tape	Supports connection to external USB tape products
NAS/IDM appliance	Software Supports NAS software stack
JBOD	Supports connection to 12 Gb MD-series JBODs

Topics:

- [IDSDM or vFlash card](#)
- [Boot Optimized Storage Subsystem \(BOSS\)](#)
- [Optical drives](#)
- [Tape Drives](#)
- [Boot Optimized Storage Subsystem](#)

IDSDM or vFlash card

In the PowerEdge R640 system, the IDSDM module contains the Internal Dual SD Module (IDSDM) and vFlash card that are combined into a single card module. The following are options available for PowerEdge R640 system:

- vflash only
- IDSDM only
- vflash + IDSDM

 NOTE: The IDSDM only option is available with vFlash hardware and requires an iDRAC Enterprise license to enable this feature.

The IDSDM with vFlash module has a dedicated slot at the back of the system chassis. This is a Dell EMC-proprietary PCIe x1 slot that uses a USB 3.0 interface to host. In the PowerEdge R640 systems, the IDSDM and vFlash card size changes from SD to microSD and the supported capacity for IDSDM microSD cards are 16 GB, 32 GB, or 64 GB, while for vFlash the capacity is 16 GB only. The write-protect switch is built onboard on the IDSDM module.

Boot Optimized Storage Subsystem (BOSS)

BOSS is offered as a means of booting 14G servers to a full OS when:

- A solution such as IDSDM may be desired, but the target OS is a full OS (not just a hypervisor)
- The user does not wish to trade off standard hot plug drive slots for OS install
- A separate hardware RAID is required for OS boot so that data drives can be in Passthrough mode with an HBA

The HW RAID BOSS card is a RAID controller with a limited feature set that presents M.2 SATA-only SSDs as either Non-RAID disks or a single RAID1 volume.

Boot Optimized Storage Subsystem (BOSS)

BOSS is a simple RAID solution card that is designed specifically for booting the system's operating system, which supports up to two 6 Gbps M.2 SATA drives. This card has a x8 connector using PCIe gen 2.0 x2 lanes, available only in the low-profile and half-height form factor.

Optical drives

The PowerEdge R440 supports one of the following internal optical drive options:

- DVD-ROM
- DVD+ROM

Tape Drives

The R440 do not support internal tape drives. However, external tape backup devices are supported on R440.

Supported external tape drives:

- External RD1000 USB
- External LTO-5, LTO-6, LTO-7 and 6 Gb SAS tape drives
- 114X rack mount chassis with LTO-5, LTO-6, and LTO-7 6Gb SAS tape drives
- TL1000 with LTO-5, LTO-6, and LTO-7 6 Gb SAS and 8GB FC tape drives
- TL2000 with LTO-5, LTO-6, and LTO-7 6 Gb SAS and 8GB FC tape drives
- TL4000 with LTO-5, LTO-6, and LTO-7 6 Gb SAS and 8GB FC tape drives
- ML6000 with LTO-5, LTO-6, and LTO-7 6 Gb SAS and 8GB FC tape drives

Boot Optimized Storage Subsystem

The Boot Optimized Storage Subsystem (BOSS) is an alternative, high speed location to install the operating system. This ensures that the drive based storage is not used by the operating system. BOSS is a simple RAID solution card designed specifically for booting the system's operating system, which supports up to two 6 Gbps M.2 SATA drives. This card has a x8 connector using PCIe gen 2.0 x2 lanes, available only in the low-profile and half-height form factor.

NOTE: The BOSS is recommended for non-virtualized operating systems. Virtualized operating systems are best supported by the iDSDM.

BOSS is an half height PCIe M.2 SATA carrier card that installed on a PCIe slot to draw power and provide system management bus sideband access into the BOSS's thermal field replacement unit (TFRU). The TFRU controls BOSS's localized active cooling fan solution and provide status to iDRAC. SATA data is exposed via the NPIO connector that is cabled to the system board or backplane.

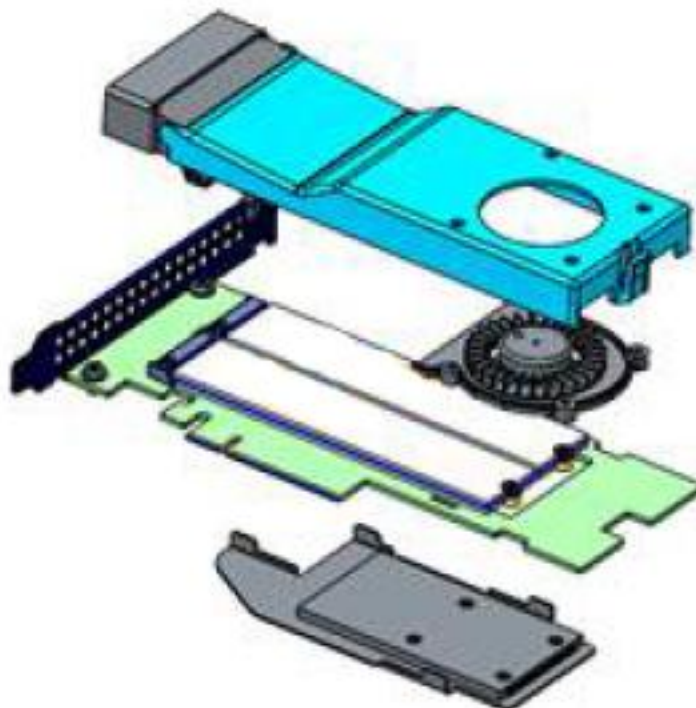



Figure 6. Boot Optimized Storage Subsystem (BOSS)

Table 13. BOSS RAID controller features

Function/Feature	Supported
Stripe size supported	64k
Configuration (HII)	Yes

Function/Feature	Supported
Full initialization	No
Fast initialization	Yes  NOTE: Performed on virtual disk creation by default.
Background initialization	No

Networking and PCIe

The PowerEdge R440 offers balanced, scalable I/O capabilities, including integrated PCIe 3.0-capable expansion slots. Dell EMC Network Daughter Cards allow you to choose the right network fabric without using up a valuable PCI slot. You can pick the speed, technology, vendor, and other options, such as switch-independent partitioning, which allows you to share and manage bandwidth on 10 GbE connections.

For details on the various networking cards available, talk to Dell representative or visit <https://www.dell.com/en-us/work/shop/povw/poweredge-r440> and choose the green view configurations button at the top for a full list of options.

Topics:

- [PCIe expansion cards](#)

PCIe expansion cards

The PowerEdge R440 system has one standard PCIe connector and four Speededge connectors.

The PowerEdge R440 system has the following four riser cards:

- Right riser - One x16 PCIe Gen3 for low-profile half length cards or One x16 PCIe Gen3 for full height half length cards – connected to CPU1
- Left riser - One x16 PCIe Gen3 for low-profile half length cards – connected to CPU2
- Riser 2 (LOM riser)
- Internal riser - One x8 PCIe Gen3 for low-profile half length cards

PCIe expansion card riser configurations

Table 14. PCIe expansion card riser configurations for PowerEdge R440

Expansion card riser	PCIe slots on the riser	Height	Length	Link
Riser 2 (LOM riser)	Slot 1	Low Profile	Half Length	x8
Right riser	Slot 2	Low Profile	Half Length	x16
	Slot 2	Full Height	Half Length	x16
PCIe passive bridge	Slot-integrated	Low Profile	Half Length	x8
Internal riser	Slot-integrated	Low Profile	Half Length	x8
Left riser	Slot 2	Low Profile	Half Length	x16
	Slot 3	Low Profile	Half Length	x16

Power, Thermal, and Acoustics

The lower overall system-level power draw is a result of the breakthrough system design developed by Dell EMC. The system aims to maximize performance per watt through a combination of energy efficient technologies, optimized thermal designs and intelligent fan control algorithms. The system fan control algorithms use an extensive array of sensors that automatically monitor power and thermal activity to minimize fan speeds based on system cooling requirements, reducing the power required for cooling.

Topics:

- [Power consumption and energy efficiency](#)
- [Thermal and Acoustics](#)
- [Power supply units](#)
- [Acoustical design](#)

Power consumption and energy efficiency

With the rise in the cost of energy that is coupled with increasing data center density, Dell EMC provides tools and technologies to help you realize greater performance with lower energy cost and wastage. More efficient data center usage can reduce costs by slowing the need for additional data center space. The following table lists the tools and technologies that Dell EMC offers to help you achieve your data center goals by lowering power consumption and increasing energy efficiency.

Table 15. Power tools and technologies

Feature	Description
Power supply units (PSU) portfolio	PSU portfolio includes intelligent features such as dynamically optimizing efficiency while maintaining availability and redundancy.
Tools for right-sizing	Enterprise Infrastructure Planning Tool (EIPT) is a tool that helps you to plan and tune your computer and infrastructure equipment for maximum efficiency. EIPT helps you by calculating hardware power consumption, power infrastructure, and storage. You can learn more at Dell.com/calc
Industry compliance	Dell EMC's servers are compliant with all relevant industry certifications and guidelines, including 80 PLUS, Climate Savers, and ENERGY STAR.
Power monitoring accuracy	PSU power monitoring improvements include: <ul style="list-style-type: none"> • Power monitoring accuracy of 1%, whereas the industry standard is 5% • More accurate reporting of power • Better performance under a power cap
Power capping	Use Dell EMC's systems management to set the power cap limit for your systems to limit the output of a PSU and reduce system power consumption. Dell is the first hardware vendor to leverage Intel Node Manager for circuit-breaker fast capping.
Systems management	Dell EMC's servers are compliant with all relevant industry certifications and guidelines, including 80 PLUS, Climate Savers, and ENERGY STAR. Dell OpenManage Power Center delivers group power management at the rack, row, and data center level for servers, power distribution units, and uninterruptible power supplies.
Active power management	Intel® Node Manager is an embedded technology that provides individual server- level power reporting and power limiting

Feature	Description
	<p>functionality. Dell offers a complete power management solution that is comprised of Intel Node Manager that is accessed through Dell iDRAC9 Enterprise and OpenManage Power Center that allows policy- based management of power and thermals at the individual server, rack, and data center level. Hot spare reduces power consumption of redundant power supplies.</p> <p>Thermal control of fan speed optimizes the thermal settings for your environment to reduce fan consumption and lower system power consumption. Idle power enables Dell servers to run as efficiently when idle as when at full workload.</p>
Fresh Air cooling	<p>FAC is supported with certain configuration limitations. With the thermal design and reliability of Dell products, you can have the capability to operate at excursion- based temperatures beyond the industry standard of 35°C (95°F) without impacting your availability model. This solution takes into account servers, networking, storage, and other infrastructure.</p>
Rack infrastructure	<p>Dell EMC offers some of the industry's highest- efficiency power infrastructure solutions, including:</p> <ul style="list-style-type: none"> • Power distribution units (PDUs) • Uninterruptible power supplies (UPSs) • Energy smart containment rack enclosures

Thermal and Acoustics

The system's thermal management delivers high performance through optimized cooling of components at the lowest fan speeds across a wide range of ambient temperatures from 10°C to 35°C (50°F to 95°F) and to extended ambient temperature ranges. These optimizations result in lower fan power consumption which translate to lower system power and data center power consumption.

Power supply units

Energy Smart power supplies have intelligent features, such as the ability to dynamically optimize efficiency while maintaining availability and redundancy. Also featured are enhanced power-consumption reduction technologies, such as high-efficiency power conversion and advanced thermal-management techniques, and embedded power-management features including high-accuracy power monitoring.

The system supports two hot-swappable AC power supplies with 1 + 1 redundancy, auto-sensing and auto-switching capability.

Acoustical design

Dell EMC focuses on sound quality in addition to sound power level and sound pressure level. Sound quality describes how disturbing or pleasing a sound is interpreted, and Dell EMC references several psychacoustical metrics and thresholds in delivering to it. Tone prominence is one such metric. Sound power and sound pressure levels increase with greater populations or higher utilization, while sound quality remains good even as the frequency content changes. A reference for comparison to sound pressure levels for familiar noise sources is given in the following table. An extensive description of Dell EMC Enterprise acoustical design and metrics is available in the [Dell Enterprise Acoustics](#) white paper.

Table 16. Acoustical reference points and output comparisons

Value measured at your ears		Equivalent familiar noise experience
LpA, dBA, re 20 µPa	Loudness, sones	
90	80	Loud concert
75	39	Data center, vacuum cleaner, voice must be elevated to be heard
60	10	Conversation levels
45	4	Whispering, open office layout, normal living room

Value measured at your ears		Equivalent familiar noise experience
LpA, dBA, re 20 μ Pa	Loudness, sones	
35	2	Quiet office
30	1	Quiet library
20	0	Recording studio

Rack rails

The rail offerings for the R440 system consist of two types of rails—sliding and static.

The sliding rails allow the system to be fully extended out of the rack for service. They are available with or without the optional cable management arm (CMA).

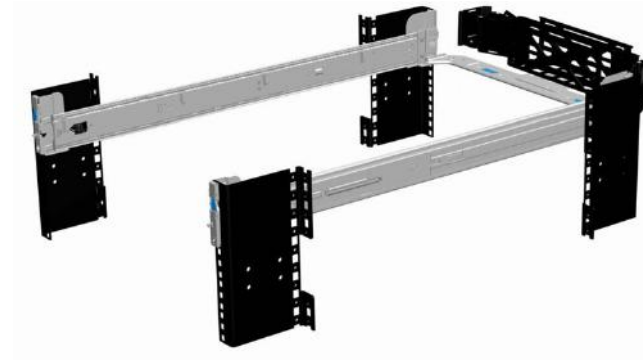

Figure 7. Sliding rails

The static rails support a wider variety of racks than the sliding rails. However, they do not support serviceability in the rack and are thus not compatible with the CMA.

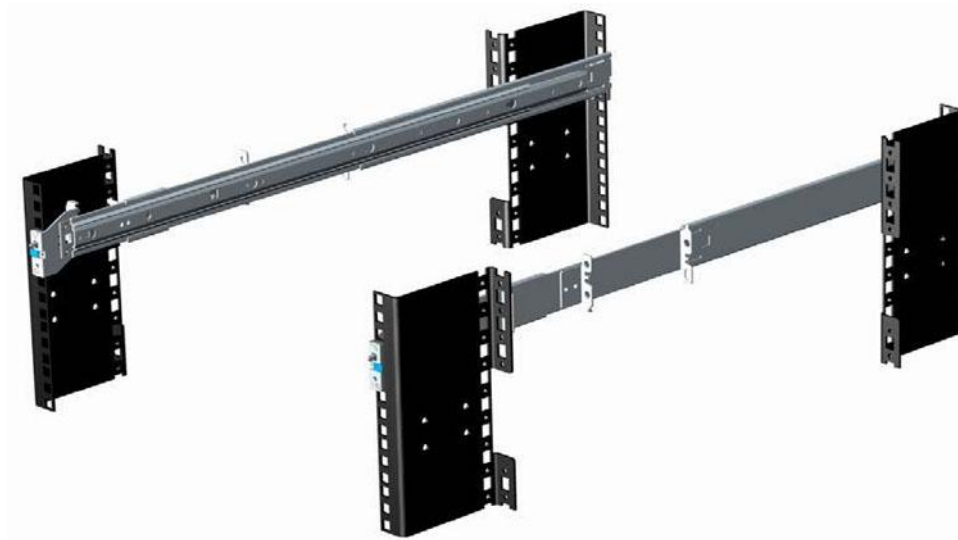

Figure 8. Static rails

One key factor in selecting the proper rails is identifying the type of rack in which they are installed. Both the sliding rails and the static rails support tool-less mounting in 19 inch-wide, EIA-310-E-compliant square hole and unthreaded round hole 4-post racks. Both also support tooled mounting in threaded hole 4-post racks, but only the static rails, as the more universal solution, support mounting in 2-post (Telco) racks.

Table 17. Static and sliding rails

Sliding and static rail

Product	Rail identifier	Mounting interface	Rail type	Rack types supported				
				4-Post			2-Post	
				Square	Round	Thread	Flush	Center
R440	B6	ReadyRails II	Sliding	√	√	√	X	X
	B4	ReadyRails	Static	√	√	√	√	√

Screws are not included in either kit as threaded racks are offered with various thread designations. Users must therefore provide their own screws when mounting the rails in threaded racks.

NOTE: Screw head diameter for the sliding rails must be 10 mm or less.

Other key factors governing proper rail selection include the following:

- Spacing between the front and rear mounting flanges of the rack
- Type and location of any equipment mounted in the back of the rack such as power distribution units (PDUs)
- Overall depth of the rack

The static rails offer a greater adjustability range and a smaller overall mounting footprint than the sliding rails. This is because of their reduced complexity and lack of need for CMA support.

Table 18. Static rails adjustability

Product	Rail identifier	Rail type	Rail adjustable range (mm)						Rail depth—mm	
			Square		Round		Threaded		Without CMA	With CMA
			Min	Max	Min	Max	Min	Max		
R440	B6	Sliding	630	883	616	876	630	897	714	845
	B4	Static	608	879	594	872	604	890	622	N/A

The adjustment range of the rails is a function of the type of rack in which they are being mounted. The Min/Max values listed above represent the allowable distance between the front and rear mounting flanges in the rack. Rail depth without the CMA represents the minimum depth of the rail with the outer CMA brackets removed (if applicable) as measured from the front mounting flanges of the rack.

Dell EMC OpenManage systems management

Dell EMC OpenManage Portfolio

Simplifying hardware management through ease of use and automation

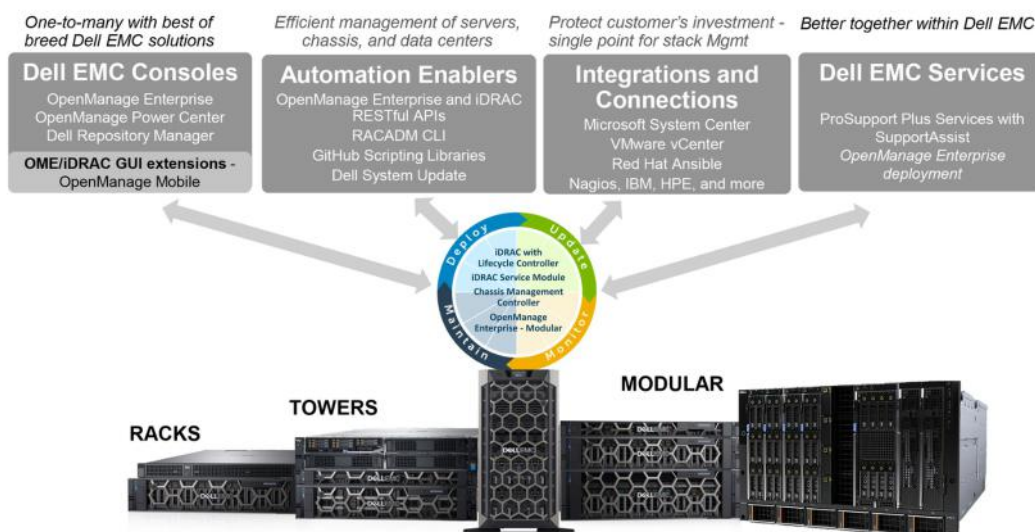

Figure 9. Dell EMC OpenManage Portfolio

Dell EMC delivers management solutions that help IT Administrators effectively deploy, update, monitor, and manage IT assets. OpenManage solutions and tools enable you to quickly respond to problems by helping them to manage Dell EMC servers effectively and efficiently; in physical, virtual, local, and remote environments, operating in-band, and out-of-band (agent-free). The OpenManage portfolio includes innovative embedded management tools such as the integrated Dell Remote Access Controller (iDRAC), Chassis Management Controller and Consoles like OpenManage Enterprise, OpenManage Power Manager plug in, and tools like Repository Manager.

Dell EMC has developed comprehensive systems management solutions based on open standards and has integrated with management consoles that can perform advanced management of Dell hardware. Dell EMC has connected or integrated the advanced management capabilities of Dell hardware into offerings from the industry's top systems management vendors and frameworks such as Ansible, thus making Dell EMC platforms easy to deploy, update, monitor, and manage.

The key tools for managing Dell EMC PowerEdge servers are iDRAC and the one-to-many OpenManage Enterprise console. OpenManage Enterprise helps the system administrators in complete lifecycle management of multiple generations of PowerEdge servers. Other tools such as Repository Manager, which enables simple yet comprehensive change management.

OpenManage tools integrate with systems management framework from other vendors such as VMware, Microsoft, Ansible, and ServiceNow. This enables you to use the skills of the IT staff to efficiently manage Dell EMC PowerEdge servers.

Topics:

- [Server and Chassis Managers](#)
- [Automation Enablers](#)
- [Integration with third-party consoles](#)
- [Connections for third-party consoles](#)
- [Dell EMC Update Utilities](#)
- [Dell resources](#)

Server and Chassis Managers

- Integrated Dell Remote Access Controller (iDRAC)
- iDRAC Service Module (iSM)

Automation Enablers

- OpenManage Ansible Modules
- iDRAC RESTful APIs (Redfish)
- Standards-based APIs (Python, PowerShell)
- RACADM Command Line Interface (CLI)
- GitHub Scripting Libraries

Integration with third-party consoles

- Dell EMC OpenManage Integrations with Microsoft System Center
- Dell EMC OpenManage Integration for VMware vCenter (OMIVV)
- Dell EMC OpenManage Ansible Modules
- Dell EMC OpenManage Integration with ServiceNow

Connections for third-party consoles

- Micro Focus and other HPE tools
- OpenManage Connection for IBM Tivoli
- OpenManage Plug-in for Nagios Core and XI

Dell EMC Update Utilities

- Dell System Update (DSU)
- Dell EMC Repository Manager (DRM)
- Dell EMC Update Packages (DUP)
- Dell EMC Server Update Utility (SUU)
- Dell EMC Platform Specific Bootable ISO (PSBI)

Dell resources

For additional information about white papers, videos, blogs, forums, technical material, tools, usage examples, and other information, go to the OpenManage page at www.dell.com/openmanagemanuals or the following product pages:

Table 19. Dell resources

Resource	Location
Integrated Dell Remote Access Controller (iDRAC)	www.dell.com/idracmanuals
iDRAC Service Module (iSM)	www.dell.com/support/article/sln310557
OpenManage Ansible Modules	www.dell.com/support/article/sln310720
OpenManage Essentials (OME)	www.dell.com/support/article/sln310714
OpenManage Mobile (OMM)	www.dell.com/support/article/sln310980
OpenManage Integration for VMware vCenter (OMIVV)	www.dell.com/support/article/sln311238
OpenManage Integration for Microsoft System Center (OMIMSSC)	www.dell.com/support/article/sln312177
Dell EMC Repository Manager (DRM)	www.dell.com/support/article/sln312652
Dell EMC System Update (DSU)	www.dell.com/support/article/sln310654

Resource	Location
Dell EMC Platform Specific Bootable ISO (PSBI)	Dell.com/support/article/sln296511
OpenManage Connections for Partner Consoles	www.dell.com/support/article/sln312320
OpenManage Enterprise Power Manager	www.dellemc.com/solutions/openmanage/power-management.htm
OpenManage Integration with ServiceNow (OMISNOW)	Dell.com/support/article/sln317784

 **NOTE:** Features may vary by server. Please refer to the product page on www.dell.com/manuals for details.

Appendix A. Additional specifications

Topics:

- Power supply specifications
- System dimensions
- Video specifications

Power supply specifications

The PowerEdge R440 systems support up to two AC power supply units (PSUs).

Table 20. Power supply specifications

PSU	Class	Heat dissipation (maximum)	Frequency	Voltage	Current
550 W	Platinum	2107 BTU/hr	50/60 Hz	100–240 V, autoranging	7.4 A – 3.7 A
450 W cabled	Bronze	1871 BTU/hr	50/60 Hz	100–240 V, autoranging	6.5 A – 3.5 A

NOTE: Heat dissipation is calculated using the PSU wattage rating.

NOTE: This system is also designed to connect to the IT power systems with a phase-to-phase voltage not exceeding 230 V.

System dimensions

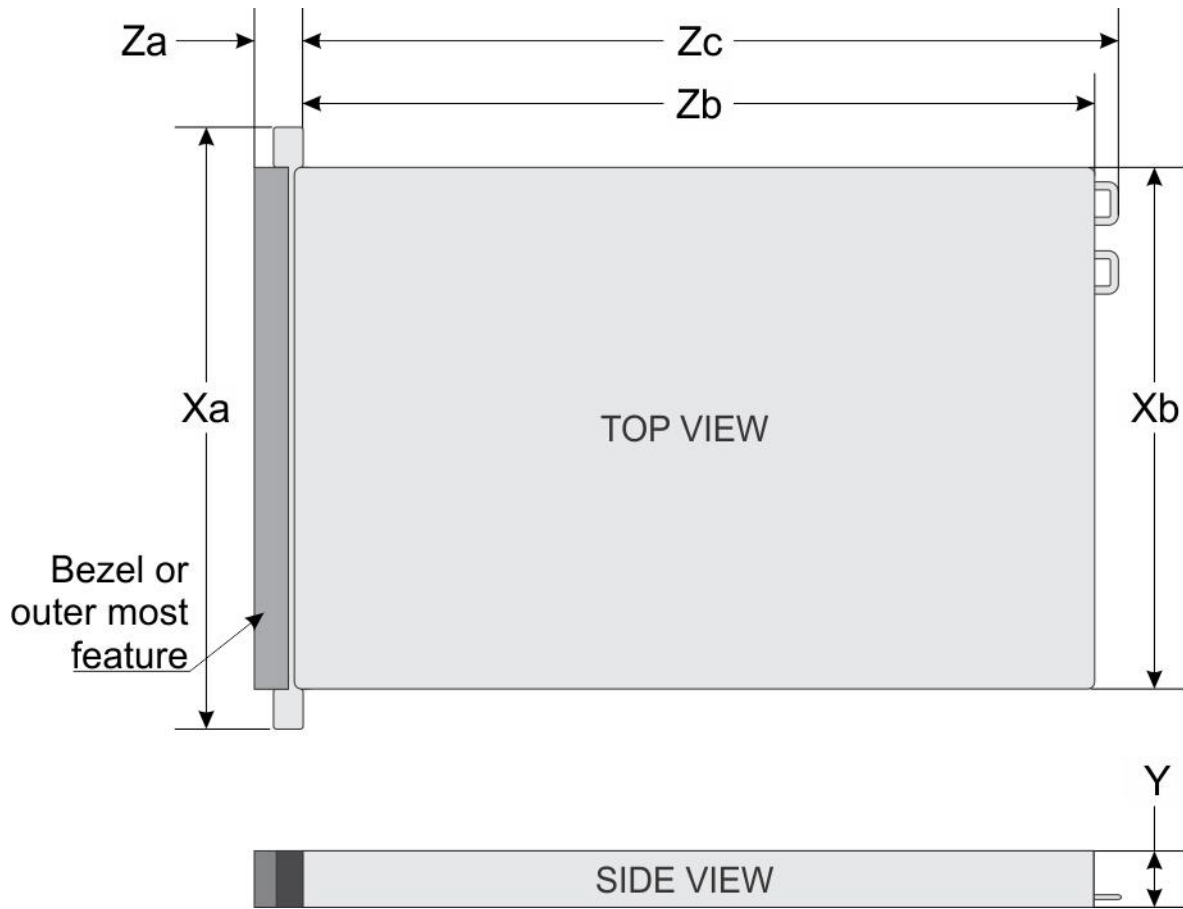

Figure 10. Dimensions of the PowerEdge R440 system

Table 21. Dimensions of the PowerEdge R440 system

System	Xa	Xb	Y	Za (with bezel)	Za (without bezel)	Zb	Zc
4 x 3.5 inch	482.0 mm (18.97 inches)	434 mm (17.08 inches)	42.8 mm (1.68 inches)	35.84 mm (1.41 inches)	22 mm (0.86 inches)	657.25 mm (25.87 inches)	692.62 mm (27.26 inches)
8 x 2.5 inch	482.0 mm (18.97 inches)	434 mm (17.08 inches)	42.8 mm (1.68 inches)	35.84 mm (1.41 inches)	22 mm (0.86 inches)	606.47 mm (23.87 inches)	641.85 mm (25.26 inches)
10 x 2.5 inch	482.0 mm (18.97 inches)	434 mm (17.08 inches)	42.8 mm (1.68 inches)	35.84 mm (1.41 inches)	22 mm (0.86 inches)	657.25 mm (25.87 inches)	692.62 mm (27.26 inches)

Chassis weight

Table 22. Chassis weight

System	Maximum weight (with all hard drives/SSDs)
Four drive bay chassis	17.64 kg (38.90 lb)
Eight drive bay chassis	16.04 kg (35.36 lb)
10 drive bay chassis	16.81 kg (37.07 lb)

Video specifications

The PowerEdge R440 system supports Matrox G200eR2 graphics card with 16 MB capacity.

Table 23. Supported video resolution options

Resolution	Refresh rate (Hz).	Color depth (bits).
640x480	60, 70	8, 16, 32
800x600	60, 75, 85	8, 16, 32
1024x768	60, 75, 85	8, 16, 32
1152x864	60, 75, 85	8, 16, 32
1280x1024	60, 75	8, 16, 32
1440x900	60	8, 16, 32

Appendix B. Standards compliance

The system conforms to the following industry standards.

Table 24. Industry standard documents

Standard	URL for information and specifications
ACPI Advance Configuration and Power Interface Specification, v2.0c	https://uefi.org/specsandtesttools
Ethernet IEEE 802.3-2005	https://standards.ieee.org/
HDG Hardware Design Guide Version 3.0 for Microsoft Windows Server	microsoft.com/whdc/system/platform/pcdesign/desguide/serverdg.mspx
IPMI Intelligent Platform Management Interface, v2.0	intel.com/design/servers/ipmi
DDR4 Memory DDR4 SDRAM Specification	jedec.org/standards-documents/docs/jesd79-4.pdf
PCI Express PCI Express Base Specification Rev. 2.0 and 3.0	pcisig.com/specifications/pciexpress
PMBus Power System Management Protocol Specification, v1.2	http://pmbus.org/Assets/PDFS/Public/PMBus_Specification_Part_I_Rev_1-1_20070205.pdf
SAS Serial Attached SCSI, v1.1	http://www.t10.org/
SATA Serial ATA Rev. 2.6; SATA II, SATA 1.0a Extensions, Rev. 1.2	sata-io.org
SMBIOS System Management BIOS Reference Specification, v2.7	dmtf.org/standards/smbios
TPM Trusted Platform Module Specification, v1.2 and v2.0	trustedcomputinggroup.org
UEFI Unified Extensible Firmware Interface Specification, v2.1	uefi.org/specifications
USB Universal Serial Bus Specification, Rev. 2.0	usb.org/developers/docs

Appendix C Additional resources

Table 25. Additional resources

Resource	Description of contents	Location
Installation and Service Manual	<p>This manual, available in PDF format, provides the following information:</p> <ul style="list-style-type: none"> • Chassis features • System Setup program • System messages • System codes and indicators • System BIOS • Remove and replace procedures • Troubleshooting • Diagnostics • Jumpers and connectors 	Dell.com/Support/Manuals
Getting Started Guide	<p>This guide ships with the system, and is also available in PDF format. This guide provides the following information:</p> <ul style="list-style-type: none"> • Initial setup steps • Key system features • Technical specifications 	Dell.com/Support/Manuals
Rack Installation Instructions	This document ships with the rack kits, and provides instructions for installing a server in a rack.	Dell.com/Support/Manuals
Information Update	This document ships with the system, is also available in PDF format online, and provides information on system updates.	Dell.com/Support/Manuals
System Information Label	The system information label documents the system board layout and system jumper settings. Text is minimized due to space limitations and translation considerations. The label size is standardized across platforms.	Inside the system chassis cover
Quick Resource Locator (QRL)	This code on the chassis can be scanned by a phone application to access additional information and resources for the server, including videos, reference materials, service tag information, and Dell EMC contact information.	Inside the system chassis cover
Energy Smart Solution Advisor (ESSA)	The Dell EMC online ESSA enables easier and more meaningful estimates to help you determine the most efficient configuration possible. Use ESSA to calculate the power consumption of your hardware, power infrastructure, and storage.	Dell.com/calc

Appendix D. Support and deployment services

ProDeploy Enterprise Suite and Residency Services

ProDeploy Enterprise Suite gets your server out of the box and into optimized production—fast. Our elite deployment engineers with broad and deep experience utilizing best-in-class processes along with our established global scale can help you around the clock and around the globe. From simple to the most complex server installations and software integration, we take the guess work and risk out of deploying your new server technology.

		Basic Deployment	ProDeploy	ProDeploy Plus
Pre-deployment	Single point of contact for project management		•	In-region
	Site readiness review		•	•
	Implementation planning		•	•
	Technology Service Manager (TSM) engagement for ProSupport Plus entitled devices			•
Deployment	Deployment service hours	Business hours	24x7	24x7
	Onsite hardware installation*	•	•	•
	Packaging materials disposal	•	•	•
	Install and configure system software		•	Onsite
	Project documentation with knowledge transfer		•	•
Post-deployment	Deployment verification		•	•
	Configuration data transfer to Dell EMC technical support		•	•
	30-days of post-deployment configuration assistance			•
	Training credits for Dell EMC Education Services			•

Figure 11. ProDeploy Enterprise Suite capabilities

NOTE: Hardware installation not applicable on selected software products.

ProDeploy Plus

From beginning to end, ProDeploy Plus provides the skill and scale needed to successfully execute demanding deployments in today's complex IT environments. Certified Dell EMC experts start with extensive environmental assessments and detailed migration planning and recommendations. Software installation includes set up of most versions of Dell EMC SupportAssist and OpenManage system management utilities. Post-deployment configuration assistance, testing, and product orientation services are also available.

ProDeploy

ProDeploy provides full service installation and configuration of both server hardware and system software by certified deployment engineers including set up of leading operating systems and hypervisors as well as most versions of Dell EMC SupportAssist and OpenManage system management utilities. To prepare for the deployment, we conduct a site readiness review and implementation planning exercise. System testing, validation, and full project documentation with knowledge transfer complete the process.

Basic Deployment

Basic Deployment delivers worry-free professional installation by experienced technicians who know Dell EMC servers inside and out.

Residency Services

Residency Services helps customers transition to new capabilities quickly with the assistance of on-site or remote Dell EMC experts whose priorities and time you control. Residency experts can provide post implementation management and knowledge transfer related to a new technology acquisition or day-to-day operational management of the IT infrastructure.

Deployment services

Deployment services details and exceptions can be found in service description documents at the Enterprise Configuration and Deployment page on Dell.com.

Remote Consulting Services

When you are in the final stages of your PowerEdge server implementation, you can rely on Dell EMC Remote Consulting Services, and our certified technical experts to help you optimize your configuration with best practices for your software, virtualization, server, storage, networking, and systems management.

Data Migration Service

Protect your business and data with our single point of contact to manage your data migration project. Your project manager will work with our experienced team of experts to create a plan using industry-leading tools and proven processes based on global best practices to migrate your existing files and data so your business system get up and running quickly and smoothly.

ProSupport Enterprise Suite

With Dell EMC ProSupport Services, we can help you keep your operation running smoothly, so you can focus on running your business. We will help you maintain peak performance and availability of your most essential workloads. Dell EMC ProSupport is a suite of support services that enable you to build the solution that is right for your organization. Choose support models based on how you use technology and where you want to allocate resources. From the desktop to the data center, address everyday IT challenges, such as unplanned downtime, mission-critical needs, data and asset protection, support planning, resource allocation, software application management and more. Optimize your IT resources by choosing the right support model.



Figure 12. ProSupport Enterprise Suite

ProSupport Plus

When you purchase PowerEdge servers, we recommend ProSupport Plus, our proactive and preventative support, for business-critical systems. ProSupport Plus provides all the benefits of ProSupport, plus the following:

- An assigned Technology Service Manager who knows your business and your environment
- Access to senior ProSupport engineers for faster issue resolution
- Personalized, preventive recommendations based on analysis of support trends and best practices from across the Dell EMC customer base to reduce support issues and improve performance

- Predictive analysis for issue prevention and optimization enabled by SupportAssist
- Proactive monitoring, issue detection, notification and automated case creation for accelerated issue resolution enabled by SupportAssist
- On-demand reporting and analytics-based recommendations enabled by SupportAssist and TechDirect

ProSupport

Our ProSupport service offers highly trained experts around the clock and around the globe to address your IT needs. We will help you minimize disruptions and maximize availability of your PowerEdge server workloads with:

- 24x7x365 access to certified hardware and software experts
- Collaborative 3rd party support
- Hypervisor and OS support
- Consistent level of support available for Dell EMC hardware, software and solutions
- Onsite parts and labor response options including next business day or four-hour mission critical

ProSupport One for Data Center

ProSupport One for Data Center offers flexible site-wide support for large and distributed data centers with more than 1,000 assets. This offering is built on standard ProSupport components that leverage our global scale but are tailored to your company's needs. While not for everyone, it offers a truly unique solution for Dell EMC's largest customers with the most complex environments.

- Team of designated Technology Services Managers with remote, on-site options
- Designated ProSupport One technical and field engineers who are trained on your environment and configurations
- On-demand reporting and analytics-based recommendations enabled by SupportAssist and TechDirect
- Flexible on-site support and parts options that fit your operational model
- A tailored support plan and training for your operations staff

Enterprise Support Services Feature Comparison			
	ProSupport	ProSupport Plus	ProSupport One for Data Center
Remote technical support	24x7	24x7	24x7
Onsite support	Next business day or Mission Critical	Next business day or Mission Critical	Flexible
Automated issue detection and case creation	●	●	●
Self-service case initiation and management	●	●	●
Hypervisor, Operating Environment Software and OS support	●	●	●
Priority access to specialized support experts		●	●
Designated Technology Service Manager		●	●
Personalized assessments and recommendations		●	●
On-demand support and utilization reports		●	●
Systems Maintenance guidance		Semiannual	Optional
Designated technical and field support teams			●

Figure 13. ProSupport One for Data Center model

Support Technologies

Powering your support experience with predictive, data-driven technologies.

SupportAssist

The best time to solve a problem is before it happens. The automated proactive and predictive technology SupportAssist* helps reduce steps and time to resolution, often detecting issues before they become a crisis. Benefits include:

- Value - SupportAssist is available to all customers at no additional charge.
- Improve productivity - replace manual, high-effort routines with automated support.
- Accelerate time to resolution - receive issue alerts, automatic case creation and proactive contact from Dell EMC experts.
- Gain insight and control - optimize enterprise devices with on-demand ProSupport Plus reporting in TechDirect and get predictive issue detection before the problem starts.

SupportAssist is included with all support plans but features vary based on service level agreement.

	Basic Hardware Warranty	ProSupport	ProSupport Plus
Automated issue detection and system state information collection	•	•	•
Proactive, automated case creation and notification		•	•
Predictive issue detection for failure prevention			•
Recommendation reporting available on-demand in TechDirect			•

Figure 14. SupportAssist model

Get started at Dell.com/SupportAssist

TechDirect

Boost your IT teams productivity when supporting Dell EMC systems. With over 1.4 million self-dispatches processed each year, TechDirect has proven its effectiveness as a support tool. You can:

- Self-dispatch replacement parts
- Request technical support
- Integrate APIs into your help desk

Or, access all your Dell EMC certification and authorization needs. Train your staff on Dell EMC products as TechDirect allows you to:

- Download study guides
- Schedule certification and authorization exams
- View transcripts of completed courses and exams

Register at techdirect.dell.com

Additional professional services

Dell Education Services

Dell Education Services offers the PowerEdge server training courses designed to help you achieve more with your hardware investment. The curriculum is designed in conjunction with the server development team, as well as Dell EMC's technical support team, to ensure that the training delivers the information and practical, hands-on skills you and your team need to confidently manage and maintain your Dell EMC server solution. To learn more or register for a class today, visit LearnDell.com/Server.

Dell EMC Global Infrastructure Consulting Services

Dell EMC Global Infrastructure Consulting Services use skilled solution architects, innovative tools, automated analysis and Dell EMC's intellectual property to give rapid insight into the root causes of unnecessary complexity. We seek better answers than traditional service models, and our strategy is to help quickly identify high-impact, short-duration projects that deliver return on investment (ROI) and free up resources. The results are practical, action-oriented plans with specific, predictable, measurable outcomes. From data center optimization to server virtualization to systems management, our consulting services can help build a more efficient enterprise.

Dell EMC Managed Services

Dell EMC Managed Services are a modular set of lifecycle services designed to help you automate and centrally configure, deploy, and manage your day-to-day data center operations. These services extend your existing on-premise IT infrastructure with off-premise cloud services designed to better address challenges with mobility, highly distributed organizations, security, compliance, business continuity, and disaster preparedness.